

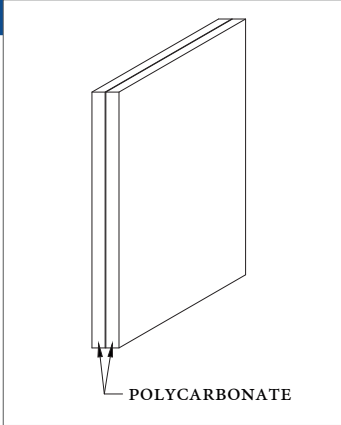

FORCEPROTECT
FORCED ENTRY RESISTANT GLASS
BY INSULGARD

LEXGARD® MPC375



Innovative glazing solutions for forced entry protection

PRODUCT DESCRIPTION

LEXGARD® MPC375 LAMINATED POLYCARBONATE GLAZING HAS BEEN TESTED TO FORCED ENTRY PERFORMANCE STANDARDS BELOW.

TECHNICAL DATA

- Nominal Thickness: .369"
- Tolerance: .332" / .406"
- Weight: 2.29 lbs per SF
- Available Sizes: Up to 72" x 96"
- Light Transmittance: 77%
- U-Value: .84
- Shading Coefficient: .92
- Translucent white interlayer available

PERFORMANCE

- Forced Entry: ASTM F1 233 Class III, ASTM 1915 Grade 3, HP White Level II-TP-0500.02 WMFL Level III

CONSTRUCTION

This product is laminated polycarbonate and contains exposed polycarbonate surfaces with abrasion resistant coatings on both sides.

INSTALLATION

All glazing should be installed in accordance with the guidelines set forth in the current edition of the Glass Association of North America (GANA) Glazing and Sealant Manuals. Glazing systems should incorporate a weep system to allow moisture and water to escape the glazing channel.

- Face Clearance 1/8" per side
- Edge Clearance 1/4"
- Bite Clearance 1"